

SPEEDGATE KINETIC



- The **SPEEDGATE KINETIC** combines security and aesthetics all in one stylish product
- Ultra high speed access with seamlessly integrated motor drive technology
- The most sophisticated product of its type in Africa
- Exported worldwide

APPLICATIONS

- Suited for applications requiring ultra high speed access and medium levels of security
- Used extensively in applications such as office receptions, airports, universities, health clubs and railways

DESIGNED FOR

- Interior and covered exterior installations (special outdoor unit for uncovered installations available on request)
- Severe operating conditions

AVAILABLE CONFIGURATIONS

- Various configurations with 900mm and 1 800mm high wings and lane widths of 600mm, 900mm and 1 100mm



UNIQUE FEATURES OF THE SPEEDGATE KINETIC

- Designed by professional engineers
- Cutting edge technology used in both the design and manufacture

RELIABLE TECHNOLOGY

- Ultra-heavy-duty high speed motor drive and gearbox
- Intelligent motor with brake system
- Built-in intelligent controller
- Low power consumption
- Green and red LED pedestrian indicator
- Motion detection sensor array – dynamic following of the pedestrian through the Speedgate Perpetual
- Highly sophisticated anti-tamper detection
 - Tailgating
 - Unauthorised direction
 - Intrusion detection
 - Physical force
- Wings reset to locked position automatically without requiring human intervention
- Safety - a series of detectors monitor the lane for safe closing

DURABLE FEATURES

CABINET

- 304 brushed stainless steel
- 3D designed and precision laser cut components
- Hand-made with expert welding
- Recess with polycarbonate infill for concealed reader mounting (option)
- Telescopic pole for facial / biometric reader mounting (option)
- LED lane status and direction indicator lights

ACRYLIC WING

- 10mm transparent acrylic (toughened glass available on request)
- Direct motor mount technology

GUARANTEED MANUFACTURED TO LAST

- 3 year mechanical guarantee
- 1 year electrical guarantee

TECHNICAL SPECIFICATIONS

POWER	220 / 110 Volt AC
OPERATING VOLTAGE	24VDC
FREQUENCY	50Hz / 60Hz
POWER CONSUMPTION	45W per lane
OPERATING TEMPERATURE	-20°C - 75°C
MATERIALS	<ul style="list-style-type: none">• CABINET: 304 brushed stainless steel• WING: 10mm transparent acrylic. Wings can be fitted with stickers of your corporate brand. Toughened glass option also available
WEIGHT	<ul style="list-style-type: none">• 90kg end cabinet• 120kg centre cabinet
PASSAGE WIDTH	<ul style="list-style-type: none">• Standard: 600mm• Special needs: 900mm• Wide: 1 100mm
WING HEIGHT	900mm (standard) / up to 1 800mm (high) Note: The maximum width available when fitted with wings of 1 800mm high is 900mm
POWER FAILURE OPERATION	Wings open automatically towards exit direction on power failure (battery backup available on request)
FIRE ALARM OPERATION	Trigger can activate barriers to remain in the open position for free access
SYSTEMS INTEGRATION	<ul style="list-style-type: none">• Integrates with all access control and time and attendance systems• Can be integrated with biometric, bar code and card readers as well as no-touch buttons and remote transmitters• Normally open dry contact / RS485
OPERATING CYCLE TIME	Open Adjustable - up to 0.25 seconds / Standard - 0.75 seconds Close
THROUGHPUT	Up to 50 persons per minute
TAMPER ALARM	<ul style="list-style-type: none">• Electronic output for a building security alert, e.g. to lock doors or activate CCTV• LED lights show red cross• Internal buzzer sounds
OPERATIONAL MODES	<ul style="list-style-type: none">• Entry and exit (standard)• Entry only• Exit only



SPEEDGATE KINETIC RANGE



SPEEDGATE KINETIC RANGE

GENERAL ARRANGEMENT OF 1 x 600mm KINETIC LANE

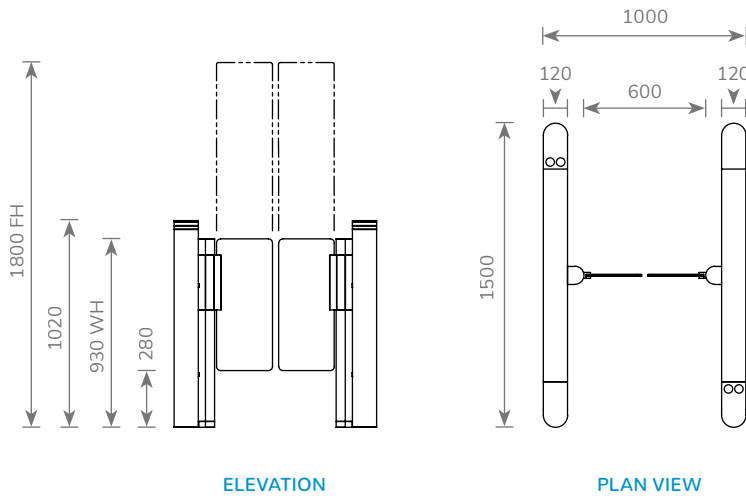

GENERAL ARRANGEMENT OF 2 x 600mm KINETIC LANES

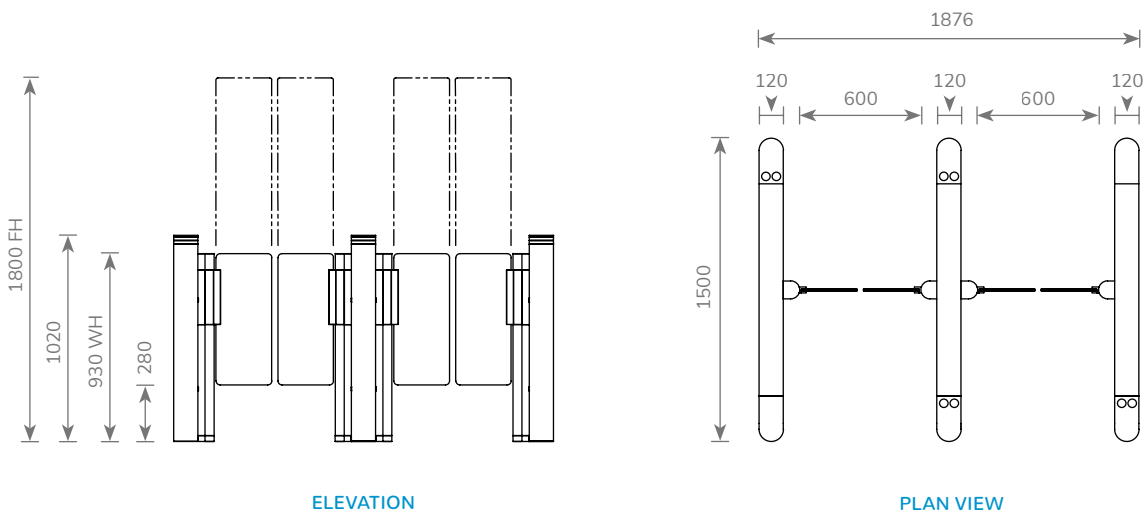

GENERAL ARRANGEMENT OF 1 x 600mm & 1 x 900mm KINETIC LANES

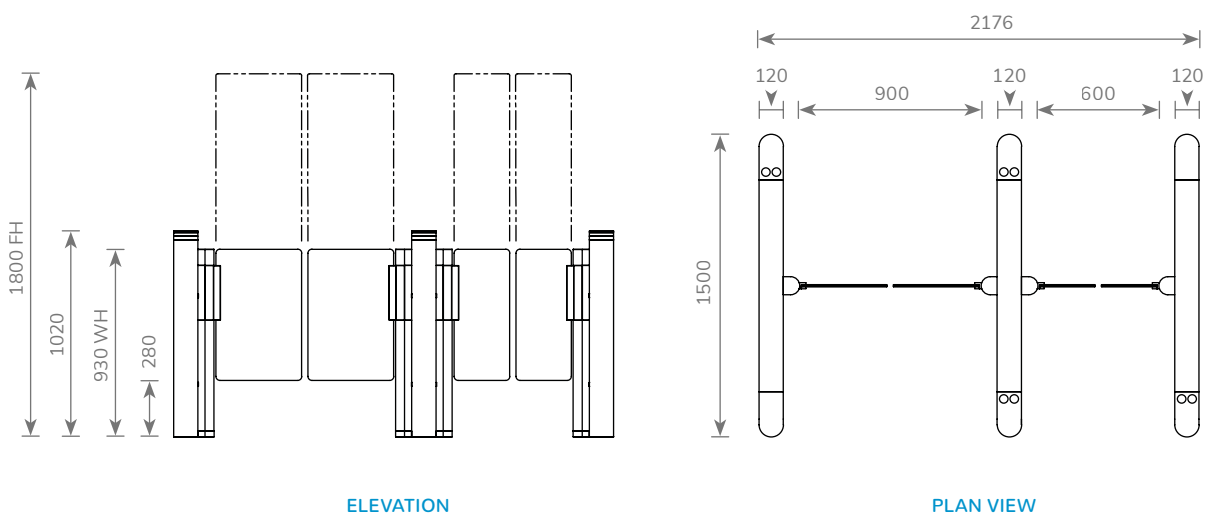

SPEEDGATE KINETIC RANGE

GENERAL ARRANGEMENT OF 1 x 1 100mm & 1 x 600mm KINETIC LANES

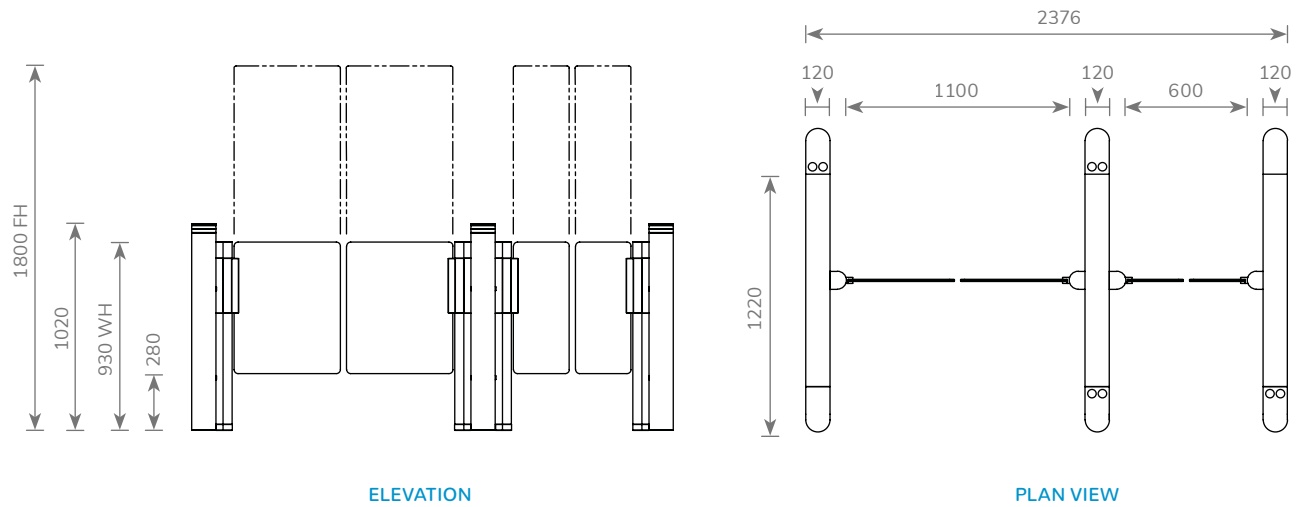

GENERAL ARRANGEMENT OF 2 x 600mm & 1 x 900mm KINETIC LANES

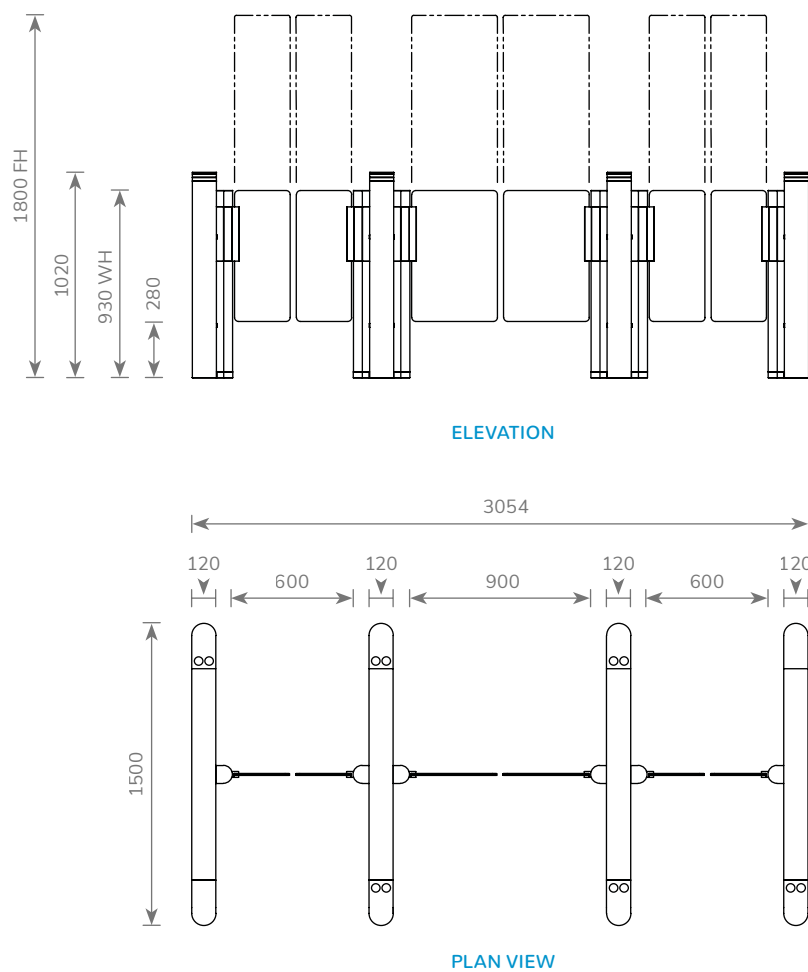

JOHANNESBURG
HEAD OFFICE AND FACTORY

+27 (0)11 786 1633

WESTERN CAPE
BRANCH

+27 (0)21 981 3043

+27 (0)82 417 7408

KWAZULU NATAL
BRANCH

+27 (0)32 947 0391

+27 (0)76 589 3410

BOLTON, UNITED KINGDOM
BRANCH

+44 (0)161 706 1760

+44 (0)7938 684 484