

DYNAMIC DROP ARM BARRIER



- Ultra slim cabinet design
- Fitted with Turnstar's industry leading SwiftDrive®
- High speed, safe and convenient access
- Allows for special needs access
- Fitted with safety sensors for peace of mind
- Now available in double drop arm

APPLICATIONS

- Suited for applications requiring medium volume access and medium levels of security
- Used extensively in applications such as office reception areas, health clubs, universities, and libraries

DESIGNED FOR

- Interior installations



TECHNICAL SPECIFICATIONS

INPUT VOLTAGE	100V – 240V AC \pm 10% at 50Hz
DRIVE	SwiftDrive®
MOTOR DETAIL	BLDC, 24V DC, 100W
GEARBOX	Planetary
MOTOR POWER SUPPLY	27.6 V DC, 4.5A, 120W
OPERATING TEMPERATURE	-15°C to +60°C
DUTY CYCLE	100% - rated for continuous non-stop operation
OPENING SPEED	1 second (adjustable for slower operation)
CLOSING SPEED	1.5 seconds (adjustable for slower operation)
POWER FAILURE OPERATION	Supplied standard with battery backup (two 12V 7Ah batteries)
COLLISION DETECTION	Motor embedded hall sensors
SAFETY CONTROL	Two optical sensors
SYSTEMS INTEGRATION	<ul style="list-style-type: none">• Integrates with all access control, ticketing and time & attendance systems• Triggered through a normally open dry contact. An extended trigger forces arm to stay down (fire alarm)
CABINET FINISH	<ul style="list-style-type: none">• 304 grade brushed stainless steel• 316 grade brushed stainless steel *• Available in black <p>* Suitable for corrosive environments</p>

SINGLE DROP ARM BARRIER WITH SKIRT



DYNAMIC DROP ARM BARRIER

DOUBLE DROP ARM
STAINLESS STEEL



SINGLE DROP ARM
BLACK FINISH



DYNAMIC DROP ARM BARRIER

SINGLE DROP ARM

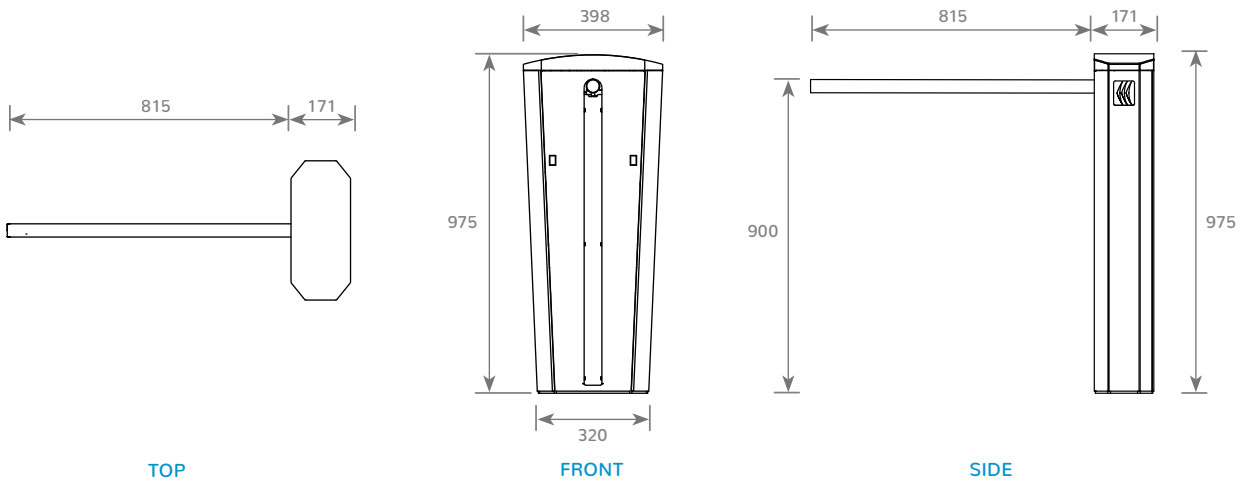

TOP

FRONT

SIDE

DOUBLE DROP ARM

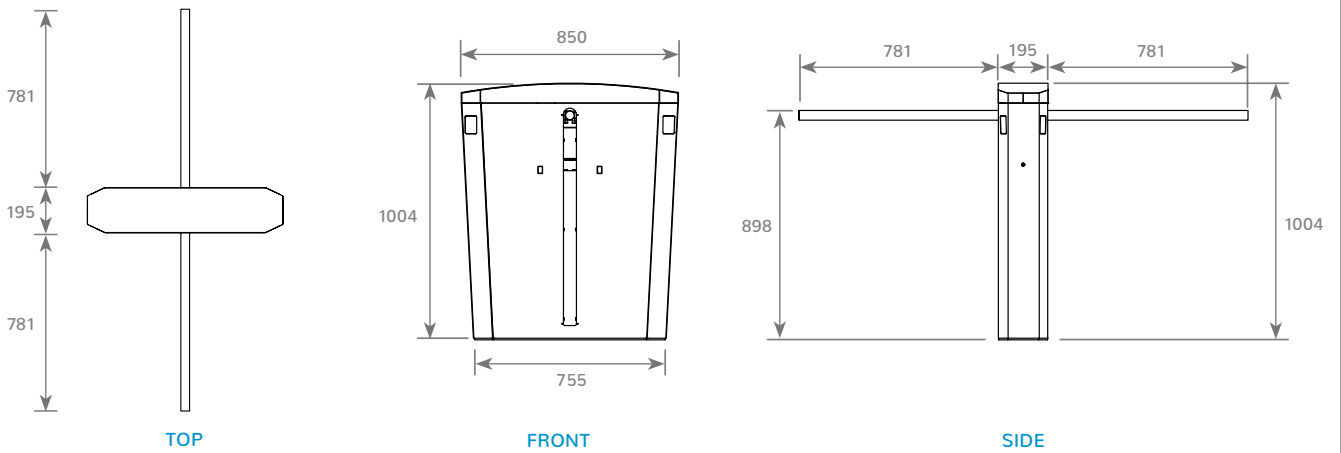

TOP

FRONT

SIDE

SINGLE DROP ARM WITH SKIRT

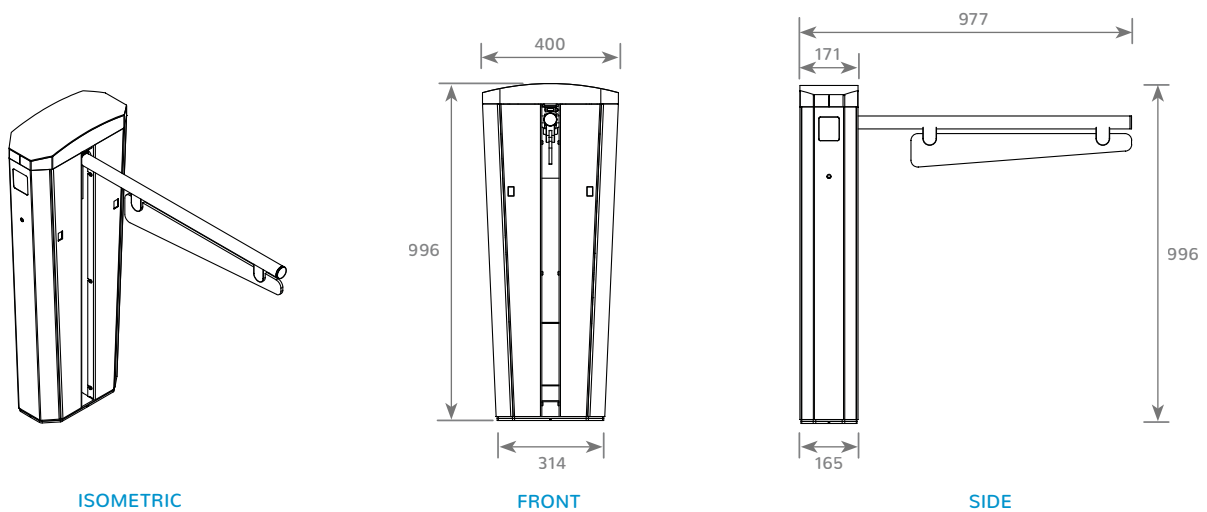

ISOMETRIC

FRONT

SIDE

© Turnstar Systems

JOHANNESBURG
HEAD OFFICE AND FACTORY

+27 (0)11 786 1633

WESTERN CAPE
BRANCH

+27 (0)21 981 3043

+27 (0)82 417 7408

KWAZULU NATAL
BRANCH

+27 (0)32 947 0391

+27 (0)76 589 3410

BOLTON, UNITED KINGDOM
BRANCH

+44 (0)161 706 1760

+44 (0)7938 684 484