

TURNSTAR

RELIABLE ★ DURABLE ★ GUARANTEED

SUPERMARKET TRIPOD TURNSTILE

WAIST HEIGHT
UNI-DIRECTIONAL TURNSTILE



SUPERMARKET HELICOPTER TURNSTILE
WITH TURNSTILE SCREEN



CHROME PLATED BARRIER RAILS

APPLICATIONS

- Suited for applications requiring one way free rotating access
- Used extensively in supermarkets and retail stores

DESIGNED FOR

- Interior installations

AVAILABLE CONFIGURATIONS

- Single
- Clockwise and anti-clockwise rotation

SECURITY RATING



ISO 9001:2015

SUPERMARKET HELICOPTER TURNSTILE

A	Required opening width	870mm	C	Turnstile arm height	900mm
B	Turnstile width	775mm	D	Overall height	960mm

PLAN

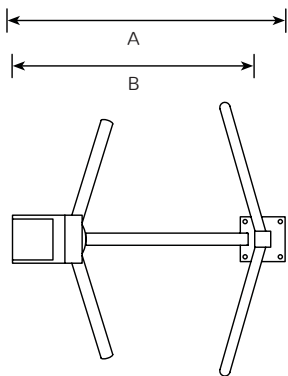

ELEVATION

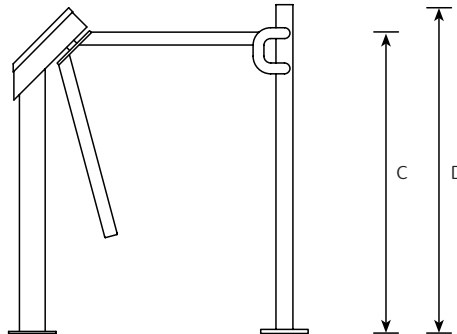

UNIQUE FEATURES

- One way free rotating access. The SUPERMARKET helicopter turnstile is a purely mechanical turnstile and is designed for free rotation either in a clockwise or anti-clockwise direction. The SUPERMARKET helicopter turnstile is not supplied with a locking mechanism or any electronics.
- Stainless steel tripod arms

MANUFACTURING OPTIONS

TURNSTILE SCREEN

SUPERMARKET helicopter turnstile screen designed to prevent the pedestrian from passing through the turnstile from the wrong way. Available in matching finish to the turnstile.

FINISH OPTIONS FOR THE TURNSTILE PEDESTAL AND SCREEN

- Mild steel with UV resistant polyester exterior powder coat finish (white) ■
- 304 grade brushed stainless steel
- 316 grade brushed stainless steel
- other colours available on request

STAR ADDITIONS

BARRIER RAIL OPTION

- 1 500mm long x 900mm high chrome plated barrier rails
- Made-to-fit barrier rails in matching finish to the turnstile

SECURITY GATE OPTION

- Made-to-fit waist height security gate in matching finish to turnstile

TROLLEY ARCH OPTION

- Made-to-fit trolley arch in matching finish to the turnstile for supermarket applications

SPECIFICATION FOR ARCHITECTS AND SPECIFIERS

Turnstar SUPERMARKET WAIST HEIGHT UNI-DIRECTIONAL TURNSTILE complete with SUPERMARKET TURNSTILE SCREEN, in finish (as per above options).

Due to our policy of continuous improvement, products are subject to change without notice. Custom designs are available on request.



info@turnstar.co.za | www.turnstar.co.za

Turnstar Systems (Pty) Ltd | Reg No: 2012/100536/07 | Established in 1990

JHB FACTORY

18 6th Street, Wynberg,
Sandton, 2090
T: +27 (0)11 786 1633
F: +27 (0)11 440 5839

CAPE BRANCH

Unit 9 Elect Park,
13 Teejay Road, Brackenfell,
Cape Town, 7560
T: +27 (0)21 981 3043

KZN BRANCH

Unit 5 - 7 Amatuli Industrial Park,
5 - 7 Eagle Road, Shaka's Head,
Umhlali, Kwazulu-Natal, 4420
T: +27 (0)32 947 0391

POSTAL ADDRESS

PO Box 41,
Highlands North,
2037



ISO 9001:2015